



TECHNICAL DATA

MASSES

Operating mass (incl. ROPS)	11,000 lbs
Operating mass (incl. Cab)	12,150 lbs
Module mass (front/rear)	4,900 lbs/6,100 lbs
Max. operating mass	11,800 lbs

DIMENSIONS

Drum width	54 in
------------	-------

COMPACTION

Nominal amplitude	0.059 in
Vibration frequency	2,100 vpm
Centrifugal force	20,000 lbs
Frequency	ECO: 1,800 VPM

PROPULSION

Speed range	0-4 mph
Tire size (10 ply)	12.5-20
Max. theoretical gradeability	52 %
Vertical oscillation	±9°
Number of pads	72
Pad area	8.2 in ²
Pad height	3 in

ENGINE

Manufacturer /Model	Yanmar 4TNV98CT-PDCE (Stage V /Tier 4f)
Type	Water cooled turbo Diesel
Rated power, SAE J1995	54 kW (72 hp) @ 2,250 rpm
Fuel tank capacity	31 gal

HYDRAULIC SYSTEM

Driving	Axial piston pump with variable displacement. Axial piston motor with constant displacement. Radial piston motor with constant displacement.
Vibration	Gear pump/motor with constant displacement.
Steering	Gear pump with constant displacem.
Service brake	Hydrostatic in forward and reverse lever.
Parking/Emergency brake	Failsafe multidisc brake in rear axle and front drum motor.

Find us locally at www.dynapac.us

We reserve the right to change specifications without notice. Photos and illustrations do not always show standard versions of machines. The above information is a general description only, all information's are supplied without liability.

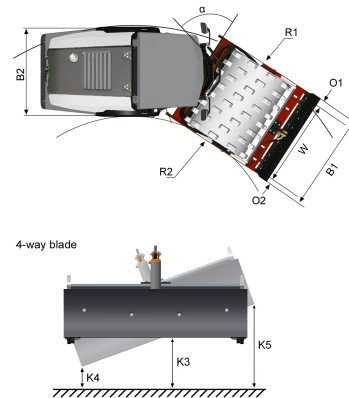
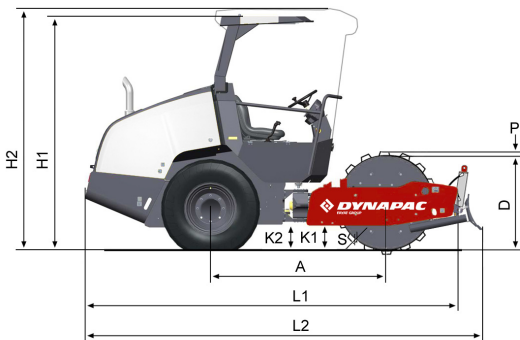

DIMENSIONS

DIMENSIONS

A. Wheelbase	73 in
B1. Width, front	59 in
B2. Width, rear	55 in
D. Drum diameter	39 in
H1. Height, with ROPS/cab	100 in
H2. Height, max.	100 in
K1. Ground clearance	10 in
K2. Curb clearance	10 in
K3. Blade clearance	12 in
K4. Blade clearance, min.	4 in
K5. Blade clearance, max.	20 in
L. Length	156 in
L1. Length	158 in
L2. Length, with strike-off blade	167 in
O1. Overhang, right	2 in
O2. Overhang, left	2 in
P. Pad height	3 in
R1. Turning radius, outside	13 ft
R2. Turning radius, inside	8 ft
S. Drum shell thickness	0.90 in
W. Working width	54 in
α. Steering angle	±33°

STANDARD EQUIPMENT

- Back up alarm
- Battery switch (std)
- Brake release
- Cup and can holder
- Differential lock (limited slip)
- Drive control (right side)
- Drum drive
- ECO mode, Emergency stop
- Engine 75 hp (Tier4final)
- Engine hood (lockable)
- Fuel level display
- High mounted exhaust pipe
- Horn, Hour meter display
- Hydraulic checkpoints
- Hydraulic fluid filter ("spin-on")
- Hydraulic fluid (mineral), Interlock
- Key (starter), Lifting points
- Lifting points for jack
- Manuals (Operation & Maintenance)
- Manuals (Spare parts catalogue)
- Operator's platform (rubber mouted)
- Operator's station (fixed), Parking brake
- ROPS (fixed) or Cab with AC/heater/ fan
- Seat (adjustable), Seat belt 3"
- Storage box (on platform)
- Storage for laminated manuals
- Tie down points
- Vandal cover (instrument panel)
- Warning lights (brake engine oil pressure engine oil temperature, Engine diagnostics low charge, low fuel level)

OPTIONAL EQUIPMENT

Air Conditioning /Automatic Climate Control (ACC) (Optional)

- The system contains fluorinated greenhouse gases.
- Coolant designation: HFC-134a
- Coolant weight when full: 0,62 kg
- CO₂-equivalent: 0,887 ton
- GWP: 1430

Find us locally at www.dynapac.us

We reserve the right to change specifications without notice. Photos and illustrations do not always show standard versions of machines. The above information is a general description only, all information's are supplied without liability.